

Parallel Circuits

Name: _____ Block: ___ Date: _____

Review:

1. A circuit in which all charge follows a single pathway is a ____ circuit; a circuit in which charge follows multiple pathways is a ____ circuit.
 - a. series, parallel
 - b. parallel, series
2. For a parallel circuit: as the number of resistors being used within the same parallel circuit increases, the overall resistance value _____ (increases, decreases) and the overall current value _____ (increases, decreases).
3. Household circuits are connected in parallel so that _____. Select all that apply.
 - a. houses get the same effect with less current and thus save on energy costs
 - b. the turning off of one appliance does not result in the shut down of others
 - c. the hazard of electrocution and overheating of circuits is avoided

Water Analogy:

4. When the water flow (or charge flow) is divided into two or more separate pathways (as in a parallel circuit) the sum of the current in each individual pathway equals the total current. Utilize this principle to fill in the blanks in the following two diagrams. The meters in the diagram are measuring water flow rates in gallons per minute ("gpm").

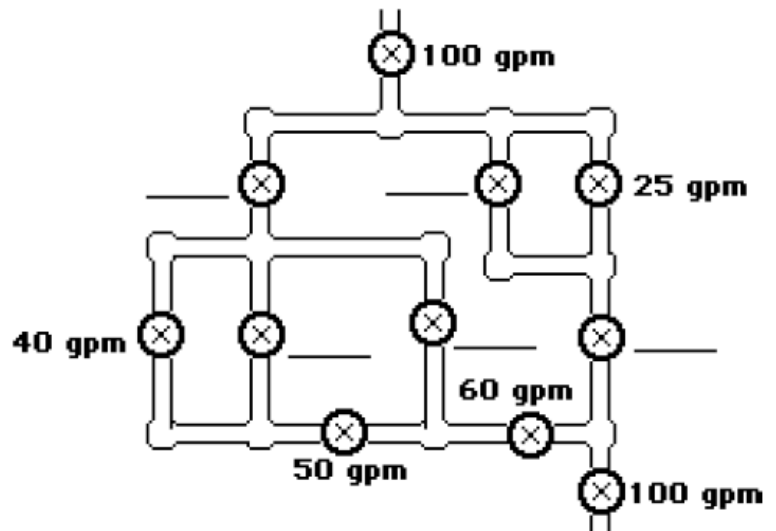
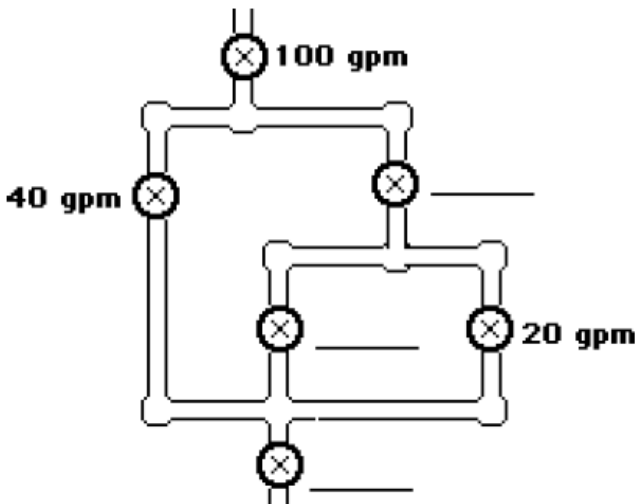

5. Apply the same principle to fill in the blanks in the following diagrams for charge flow (i.e., current) through a parallel circuit.

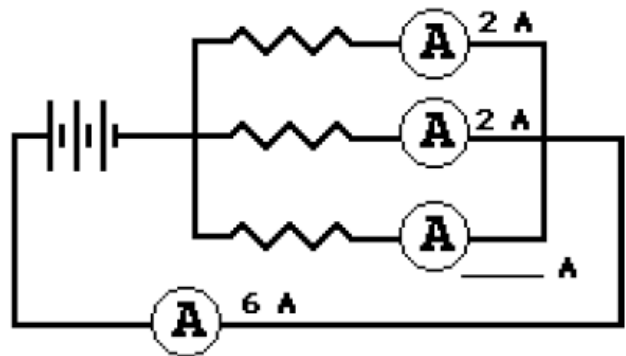
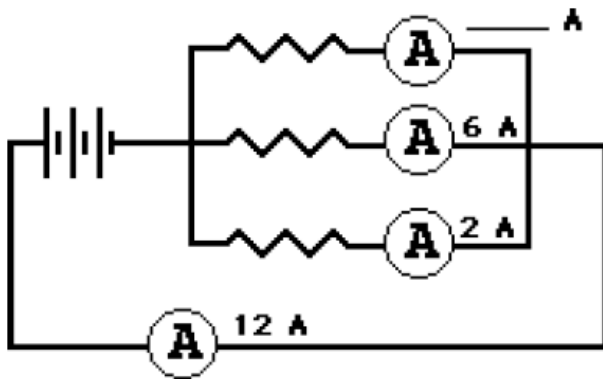

The Staircase Analogy

Electric charge dividing into multiple pathways in a parallel circuit is analogous to people walking down stairs which divide up into separate paths.

Imagine being at a large shopping mall; you are descending a rather wide stairway when all of a sudden it breaks up into several smaller stairways. Being in a hurry, you scan the different pathways down the stairs to see which path is least crowded. You finally decide that the left stairway is least crowded and make a "dash" towards it. You know that your "flow rate" will be greatest along the stairway with the least resistance. When the "people flow" divides up into multiple pathways, each pathway has the same change in height (or same gravitational potential drop); yet, the pathway that offers the least resistance will have the greatest flow rate.

In an analogous manner, as charge flow divides up into multiple pathways in a parallel circuit, each pathway has the same electric potential drop; yet, the pathway with the least resistance will have the greatest rate of charge flow (i.e., current).

6. In the following circuits, fill in the blanks to indicate the current through the different pathways. Calculate the resistance of each resistor. Then rank the resistance of the resistors (labeled A, B, and C) in order from smallest to largest.

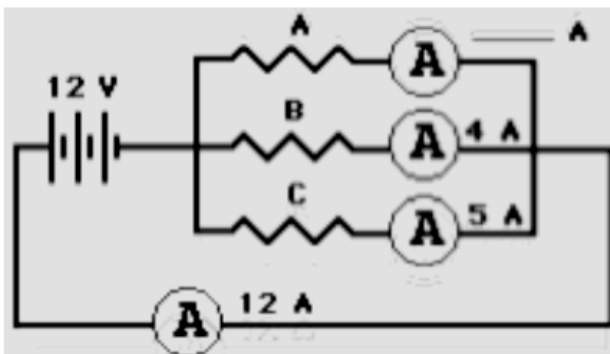

Ranking of Resistance

___ < ___ < ___

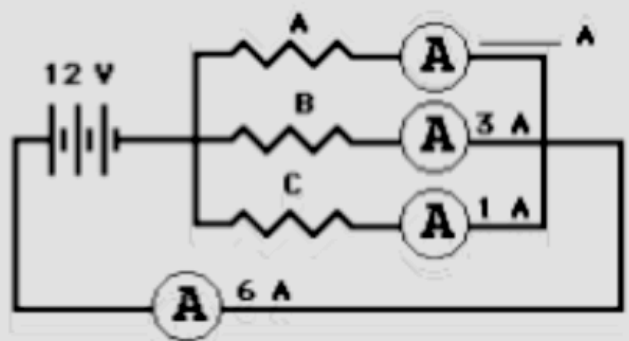

Ranking of Resistance

___ < ___ < ___

7. A three-resistor parallel circuit is created. The resistances of the resistors are $3\ \Omega$, $6\ \Omega$, and $9\ \Omega$. Suppose that one observes the current through the $3\ \Omega$ resistor to be 6 Amperes. The voltage drop across this $3\ \Omega$ resistor must be _____ V. This provides sufficient evidence to conclude that the voltage drop across the $6\ \Omega$ resistor is _____ V and the voltage drop across the $9\ \Omega$ resistor is _____ V. Therefore, the current in the $6\ \Omega$ resistor is _____ Amperes and the current in the $9\ \Omega$ resistor is _____ Amperes. When these three branch currents combine, one would observe that the current in the _____ V battery is _____ Amperes. In summary:

$$R_1 = 3\ \Omega$$

$$R_2 = 6\ \Omega$$

$$R_3 = 9\ \Omega$$

$$I_1 = 6\ \text{Amps}$$

$$I_2 = \text{___ Amps}$$

$$I_3 = \text{___ Amps}$$

$$\Delta V_1 = \text{___ V}$$

$$\Delta V_2 = \text{___ V}$$

$$\Delta V_3 = \text{___ V}$$

$$I_{\text{battery}} = \text{___ Amps}$$

$$\Delta V_{\text{battery}} = \text{___ V}$$

$$\Delta V_{\text{battery}} / I_{\text{battery}} = \text{_____}$$

8. Consider the circuit at the right.
- There is a voltage drop of _____ V across each $2\text{-}\Omega$ resistor.
 - By Ohm's law, the current in each $2\text{-}\Omega$ resistor is _____ amps.
 - The current through the battery is _____ amps.
 - The resistors in parallel offer a combined resistance of _____ Ω to the charge being pumped by the battery.

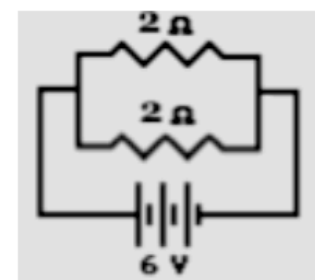

Equivalent Resistance

Devices connected in parallel offer a resistance to the flow of charge through the circuit. The total resistance (or *equivalent resistance*) is related to the resistance of the individual devices which are connected in parallel. The equivalent resistance can be determined with the equation

$$\frac{1}{R_{\text{equivalent}}} = \frac{1}{R_1} + \frac{1}{R_2} + \frac{1}{R_3}$$

The electric potential difference across each branch is the product of the equivalent resistance and the total current (outside the branches).

Use the diagram below at the right in order to answer questions #9-#13. PSYW

9. Determine the equivalent resistance of the circuit at the right.

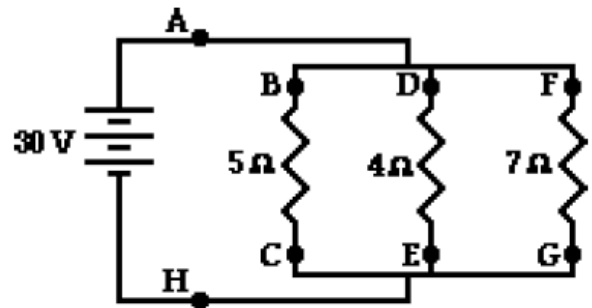

10. Determine the overall current in the circuit (as determined at position A or H).

11. Determine the electric potential difference (i.e. voltage drop) across the 5-Ω resistor (from B to C).

12. Determine the current through the 5-Ω resistor (from B to C).

13. Determine the current through the 7-Ω resistor (from B to C).

14. TRUE or FALSE:

If resistors are connected in parallel, then the electric potential difference (i.e., voltage drop) will be greatest across the resistor with the greatest resistance.

14. TRUE or FALSE:

If resistors are connected in parallel, then the current will be the same through each resistor.

15. A 2-Ω and a 4-Ω resistor are connected in a parallel circuit. The electric potential difference (i.e., voltage drop) across the 4-Ω resistor will be ___ the electric potential difference across the 2-Ω resistor.



- a. two-times more than b. two times less than c. the same size as

16. A 2-Ω and a 4-Ω resistor are connected in a parallel circuit. The current through the 4-Ω resistor will be ___ the current through the 2-Ω resistor.

- a. two-times more than b. two times less than c. the same size as

Parallel Circuits

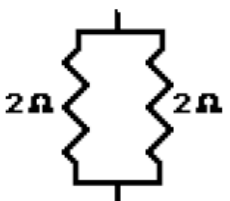
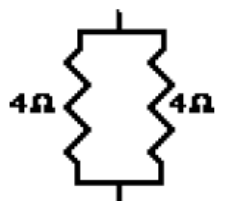
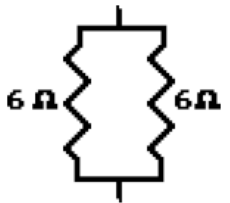
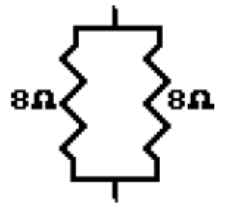
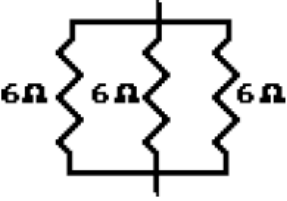
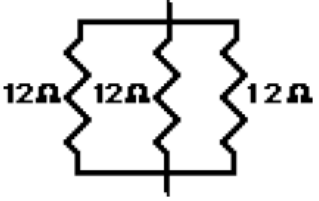
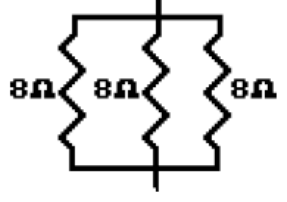
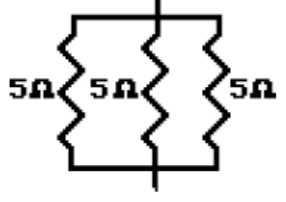
17. For each of the following branched systems, determine the equivalent resistance.

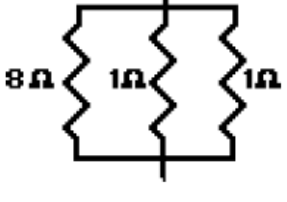
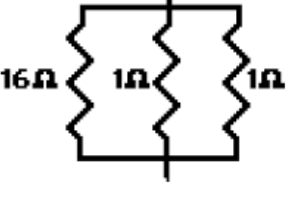
<p>a.</p>  <p>is equivalent to _____ Ω</p>	<p>b.</p>  <p>is equivalent to _____ Ω</p>
<p>c.</p>  <p>is equivalent to _____ Ω</p>	<p>d.</p>  <p>is equivalent to _____ Ω</p>
<p>e.</p>  <p>is equivalent to _____ Ω</p>	<p>f.</p>  <p>is equivalent to _____ Ω</p>
<p>g.</p>  <p>is equivalent to _____ Ω</p>	<p>h.</p>  <p>is equivalent to _____ Ω</p>
<p>i.</p>  <p>is equivalent to _____ Ω</p>	<p>j.</p>  <p>is equivalent to _____ Ω</p>
<p>k.</p>  <p>is equivalent to _____ Ω</p>	<p>l.</p>  <p>is equivalent to _____ Ω</p>

18. Four resistors are connected in a parallel circuit. Three of the resistance values are known - 3 Ω, 4 Ω and 6 Ω. The overall or equivalent resistance of the four resistors must be _____ Ω. (Choose the one answer that is most informative.)

a. greater than 3

b. greater than 6

c. greater than 13

d. less than 13

e. less than 3

f. ... it is impossible to tell.